

A ←



Motor aero in double system (Hydro/Aero)
Motor aero v kombinovaném systému (Hydro/Aero)



Motor of single system (Hydro or Aero) or hydro motor in double system (Hydro/Aero)
Motor jednoduchého systému (Hydro nebo Aero) nebo motor hydro v kombinovaném systému (Hydro/Aero)



Electronic control or LCD / Elektronické ovládání



Cleanpool (combination of pneumatic control and cleanpool is not possible)
Čištění (kombinace mechanického ovládání a čištění není možná)



Pneumatic control (combination of pneumatic control and cleanpool is not possible)
Mechanické ovládání (kombinace mechanického ovládání a čištění není možná)

Inspection hatches / Servisní otvor

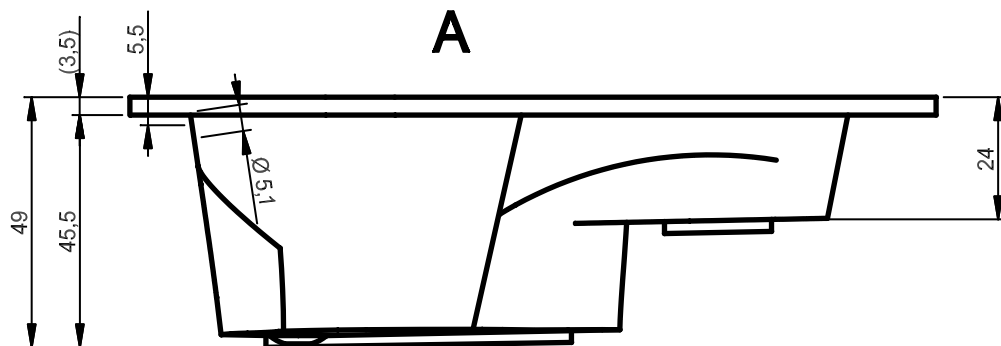

Treatment:

Material: Acryl 4mm

Rev.	Change	no	Dev.	Date	Rev.	Change	no	Dev.	Date	Rev.	Change	no	Dev.	Date	Rev.	Change	no	Dev.	Date	
A					C					E					G					
B					D					F					H					

Scale: 1:15 Format: A4 Unit: cm Sheet: 1 of 1 Tolerance: NEN-ISO 2768-1 class v

Name: Neo 150x150

Linedrawing

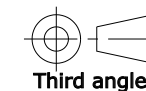

Third angle

TILBURG HOLLAND Tel: 0031135720225 Fax: 0031135720202	Drawn: LH Introduced by tech. change 76/2005 Article nr.:	Date: 14-12-2005	Project no. 10.132 Draw. no.: BC350000
---	---	------------------	---